

# Technical manual for the electronic of the multi touch table

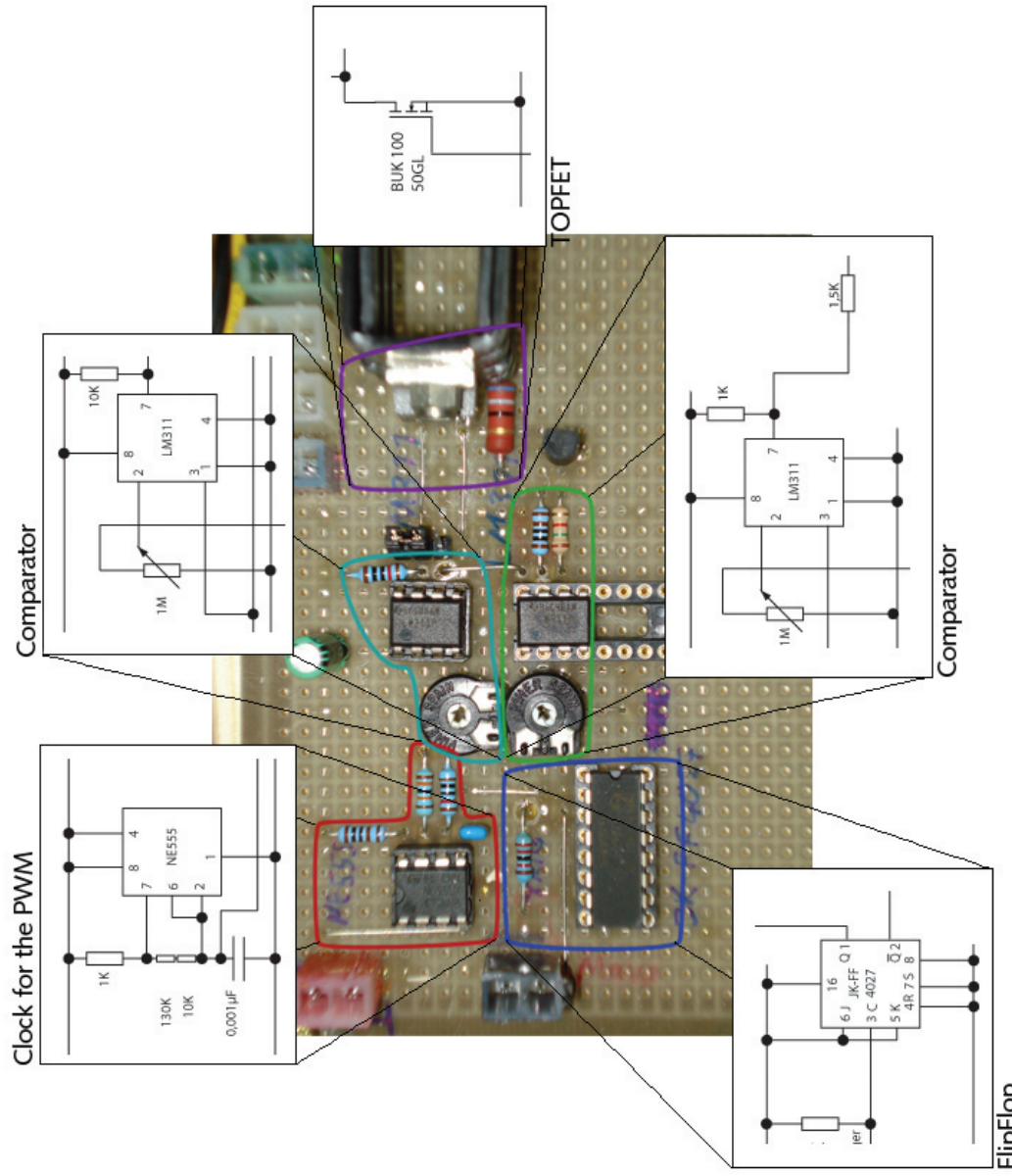
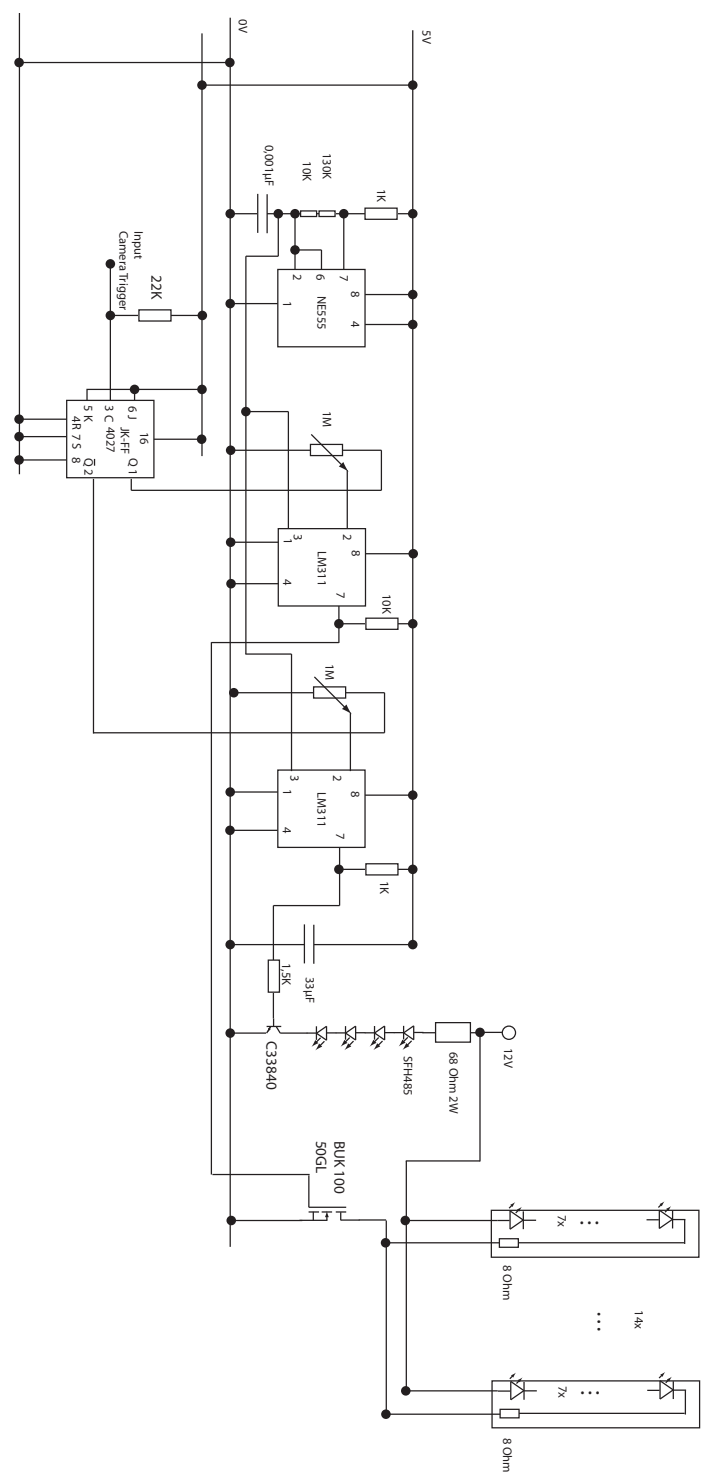

## Connect the Devices

5V Supply

Corner LEDs Main LEDs 12V Supply

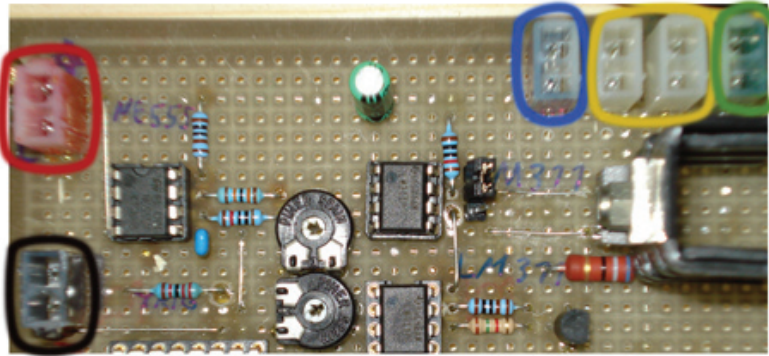

Camera Input

The sockets are colour coded, you just have to plug the corresponding plugs in the sockets. There are two plugs and two sockets for the main LEDs, it is of no importance in which of the two you plug them in.

## Brightness Control

These two controllers regulate the brightness of the main and corner LEDs. You can move them as you like this will not harm the electronic.

Brightness control main LEDs

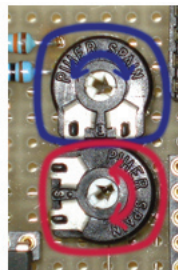

Brightness control corner LEDs

## Jumper Position

If the jumper is in the upper position the system works in *normal mode*, it is said the corner and the main LEDs are switched on alternatingly.

If the jumper is in the lower position the system is in *testing mode* and the main LEDs and the corner LEDs are switched on and off at the same time.

Normal mode

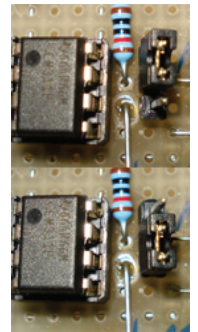

Testing mode

## Maintenance Advices

If a panel does not seem to work, you can easily unplug it and repair it. The plugs fit through the holes, you just have to try to get them out. To check if a panel is broken connect it and look straight in the LEDs if you see a slight reddish glow it is OK.